

# Correct Identification of the mount flange

Directions to measure :

- 1) Print out this copy of template in full size
- 2) Cut out the starter flange template below
- 3) Mark the mount holes from engine block onto the template.
- 4) Measure the pitch center diameter through center of mount holes, note down in millimeters.
- 5) Remember to measure the diameter of mount holes.
- 6) Mark any restrictions on either side of mount holes.

Pitch center diameter through  
center of mount holes

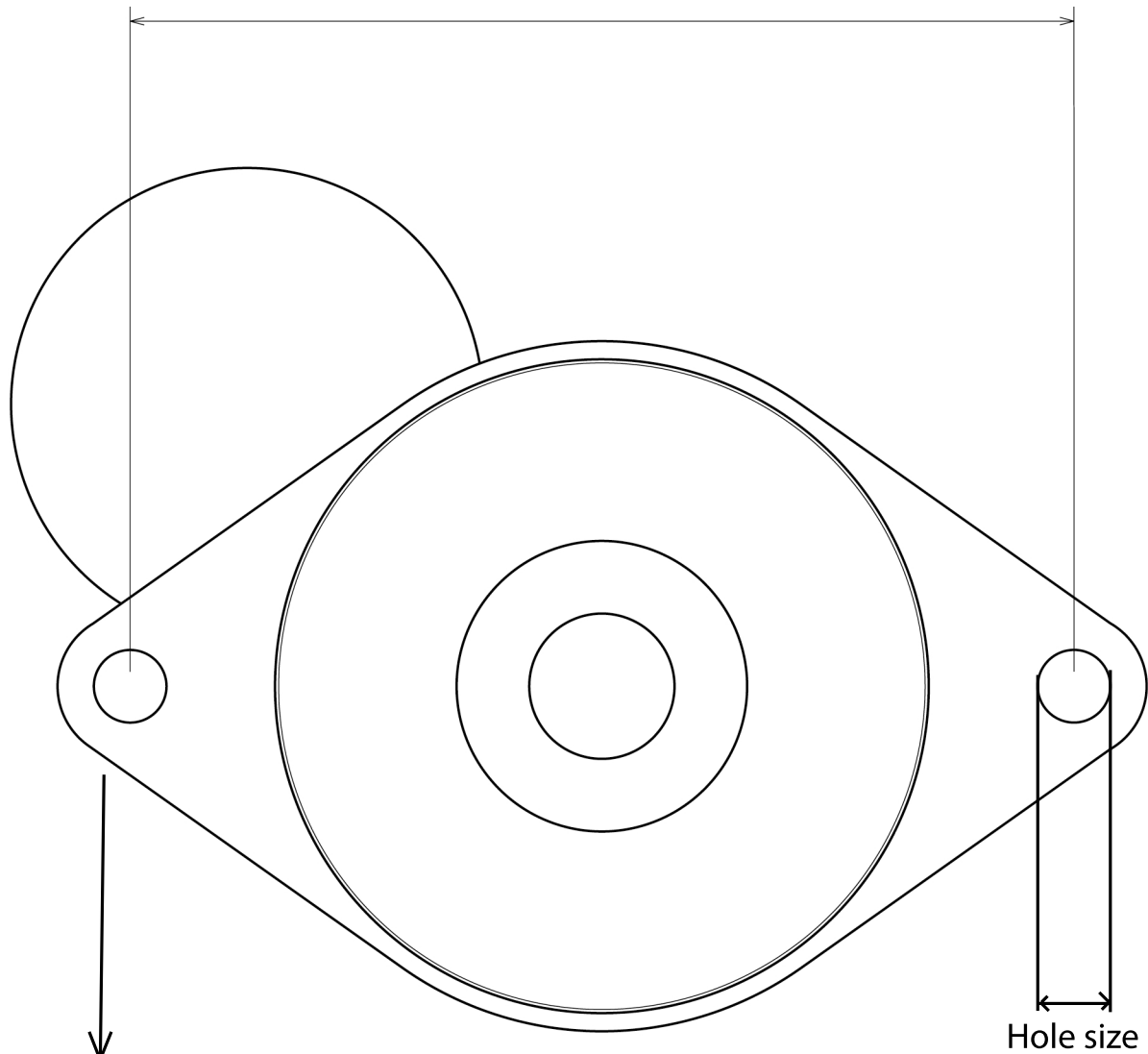

Any restrictions on either side

Scale: 1:1

# Correct identification of motor solenoid restrictions

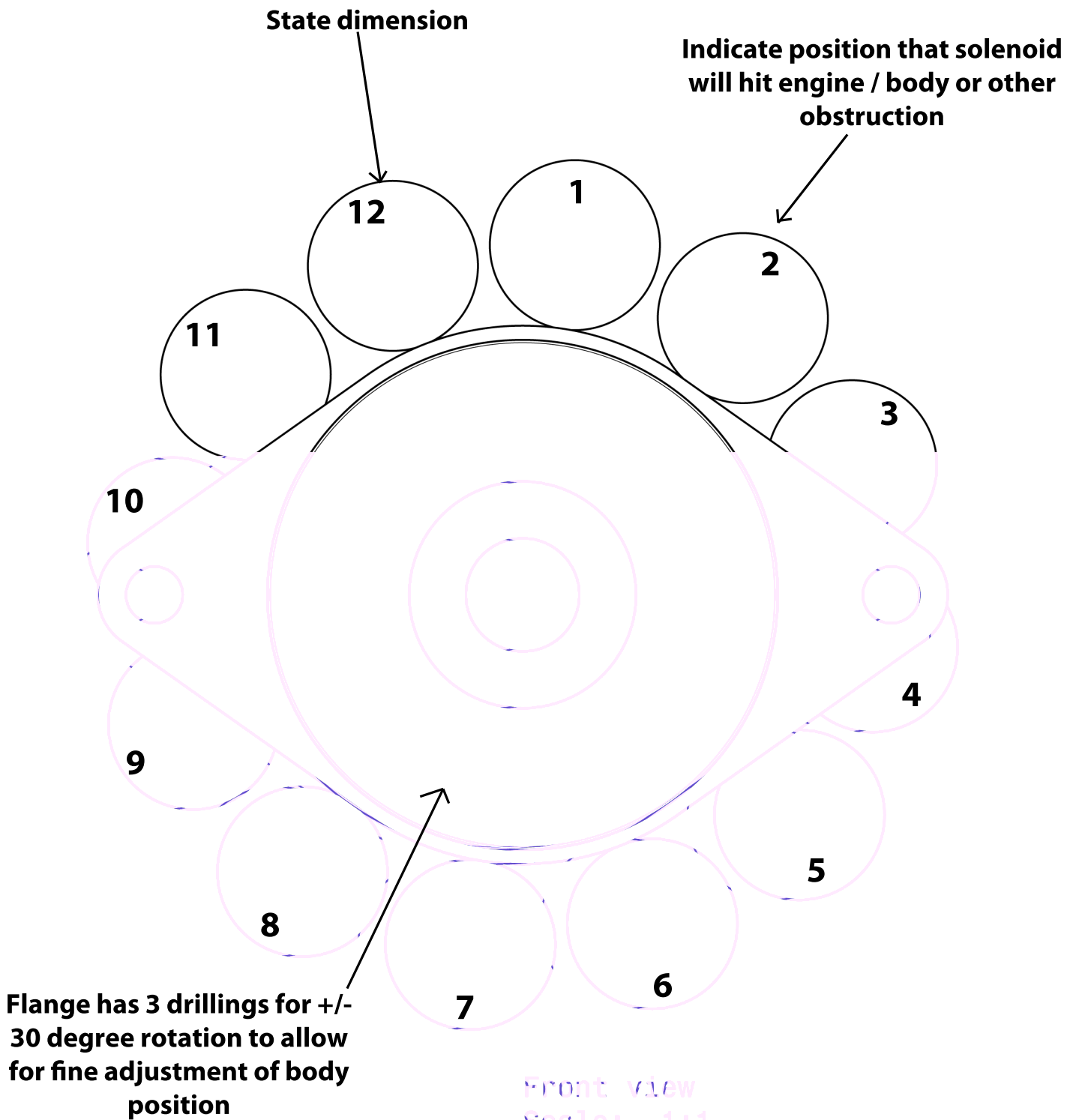

# Template for flange with 3 mounting holes

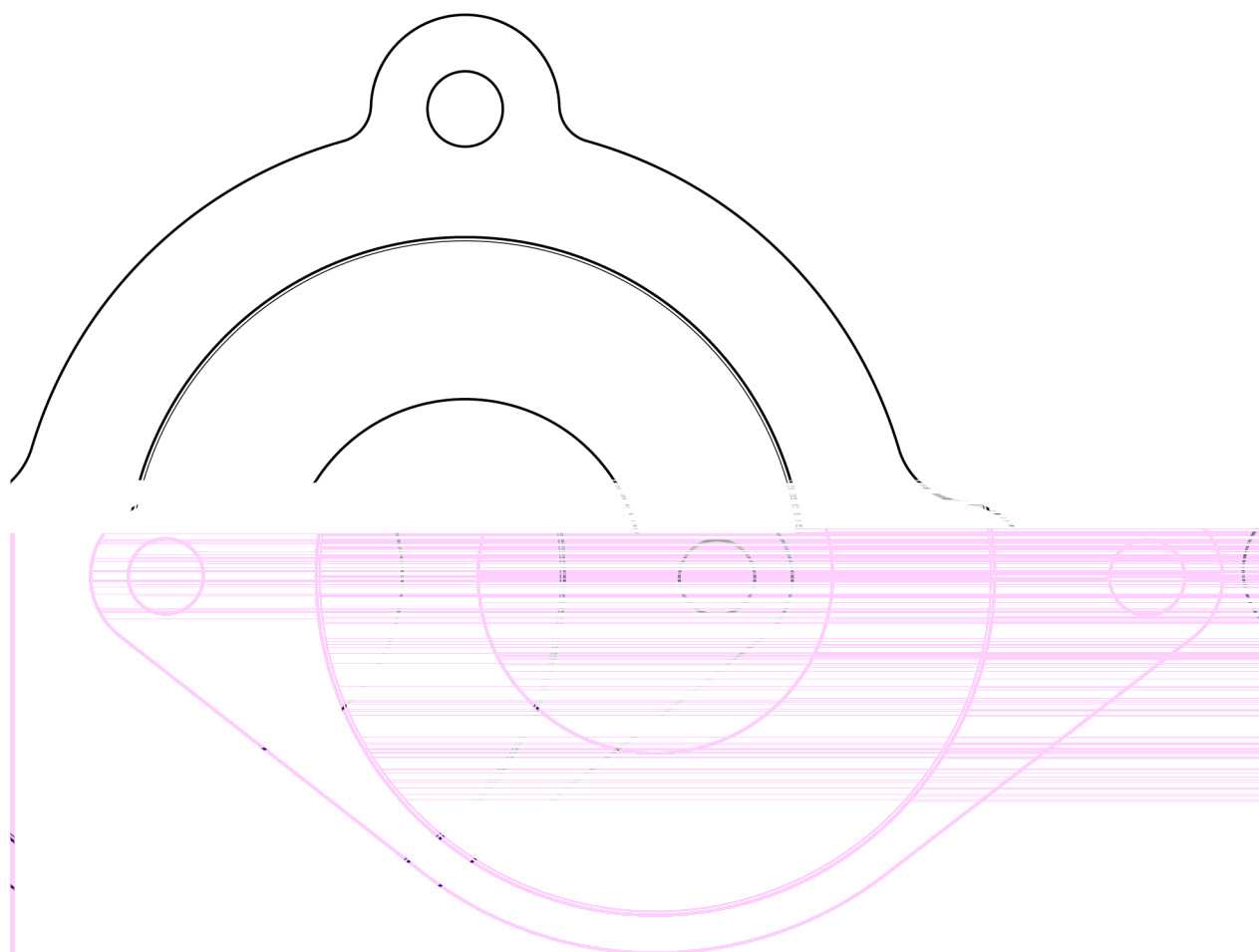

Front view

Scale: 1:1